



AIR TORQUE

AIR TORQUE S.p.A.
 via Alla Campagna, N° 1
 24060 Costa di Mezzate (Bg) Italy
 Tel.: +39 035 682299
 Fax: +39 035 687791
 E-mail: info@airtorque.it



**Material for
 AT051U and AT101U
 D/S - 90°**

TDS n° AT051U + AT101U-MC
 Issued on: 10/09 - Page 1/1

Material and Construction

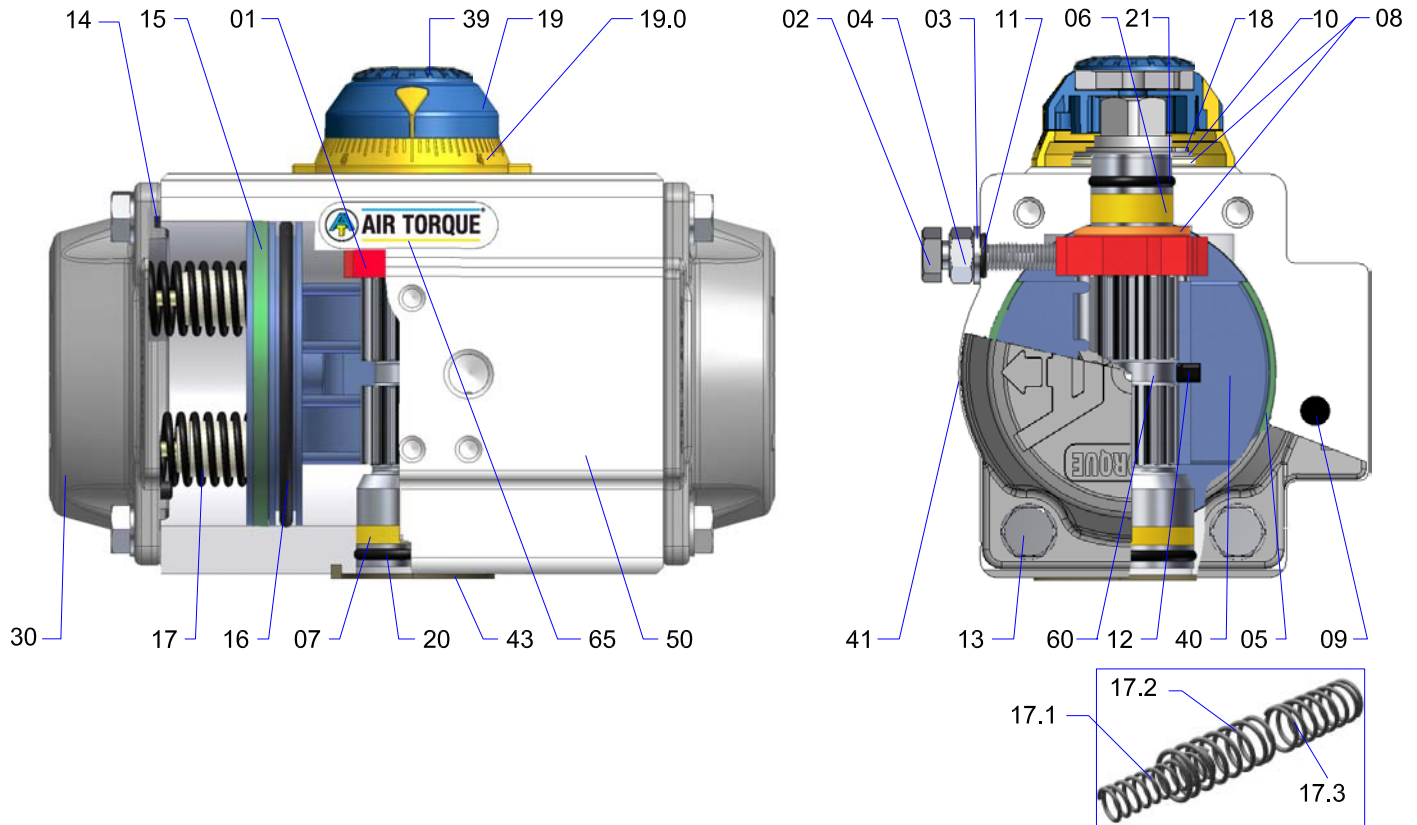

PART N°	Spare Parts	UNIT Q.TY / NOTE	PART DESCRIPTION	STANDARD MATERIAL (A) (B)
01		1	OCTI-CAM (Stop arrangement)	Stainless Steel
02		2	STOP CAP SCREW	Stainless Steel
03		2	WASHER	Stainless Steel
04		2	NUT (Stop screw)	Stainless Steel
05	○	2	BEARING (Piston back)	PA46
06	○	1	BEARING (Pinion top)	PA46
07	○	1	BEARING (Pinion bottom)	PA46
08	○	2	THRUST BEARING (Pinion)	PA46
09	○ □	2	PLUG	Silicone
10		1	THRUST WASHER (Pinion)	Stainless Steel
11	○ □	2	"O" RING (Stop screw)	M-NBR
12		2	PISTON GUIDE	PA66+GF
13		8	CAP SCREW (End cap)	Stainless Steel
14	○ □	2	"O" RING (End cap)	M-NBR
15	○	2	BEARING (Piston head)	POM
16	○ □	2	"O" RING (Piston)	M-NBR
17		min. 5 max. 12	<i>only for AT101U</i> SPRING (Cartridge)	
17.1			SPRING	SiCr Spring alloy Steel epoxy coated
17.2		min. 2 max. 4	<i>only for AT051U</i> SPRING	
17.3			SPRING	
18		1	SPRING CLIP (Pinion)	Spring Steel, ENP
19		1	POSITION INDICATOR	PA66+GF+CB
19.0		1	GRADUATED RING	PA66+GF(+CB)
20	○ □	1	"O" RING (Pinion bottom)	M-NBR
21	○ □	1	"O" RING (Pinion top)	M-NBR
30		2	END CAP	Pressure Die Cast Aluminium alloy, anodized and coated
39		1	CAP SCREW (Indicator)	PA66+GF+CB
40		2	PISTON	Pressure Die Cast Aluminium alloy, anodized
41		1	ACTUATOR IDENTIFICATION LABEL	Polyester-Silver
43		1	SPIGOT (Only on request)	Extruded Aluminium alloy, anodized
50		1	BODY	Extruded Aluminium alloy, coated
60		1	DRIVE SHAFT	Steel, ENP
60.1		1	<i>only for protection level "E" and "F"</i> INTEGRAL DRIVE SHAFT	Stainless Steel, ENP
65		1	PLASTIC INSERT	Modified PA66

○ Parts included in Complete spare parts kit

□ Parts included in "O" ring spare parts kit

Notes: A) For detail of material end coating specifications refer to T.D.S. U00400AE ÷ U00400PE.
 B) For different soft parts material depending on operating temperature range refer to T.D.S. U00501E.